

TV East/West correction circuit for square tubes

Technology: Bipolar

Features

- Low dissipation
- Square generator for parabolic current specially designed for square C.R.T. correction
- External keystone adjustment (symmetry of the parabola)
- Input for dynamic field correction (beam current change)
- Static picture width adjustment
- Pulse-width modulator
- Final stage D-class with energy redelivery
- Parasitic parabola suppression, during flyback time of the vertical sawtooth

Case: 8 pin dual inline plastic

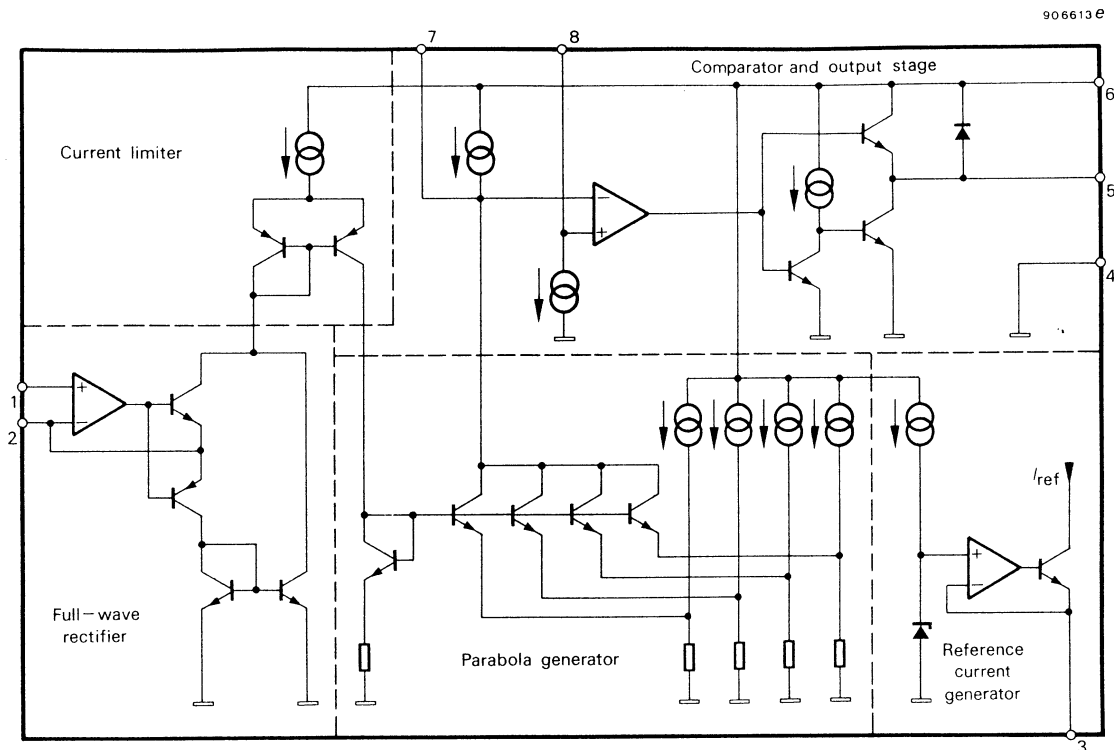

Figure 1 Block diagram

Absolute Maximum Ratings

Parameters	Symbol	Value	Unit
Supply voltage	Pin 6 V_S	35	V
Supply current	Pin 6 I_S	500	mA
Substrate current	Pin 5 $-I_5$	400	mA
Power dissipation	$T_{case} = 50^\circ C$ P_{tot}	500	mW
Storage temperature range	T_{stg}	-25 to +150	$^\circ C$
Junction temperature	T_j	-25 to +150	$^\circ C$

Electrical Characteristics

$V_S = 26\text{ V}$, $T_{\text{amb}} = 25^\circ\text{C}$, Test circuits 1 to 5

Parameters	Test Conditions / Pins	Symbol	Min.	Typ.	Max.	Unit
Supply voltage range	Pin 6	V_S	17	24	30	V
Supply current,	Test circuit 1 Pin 6	I_S		4.5	7	mA
Reference voltage	Test circuit 1 Pin 3	V_{ref}	7.6	8.0	8.8	V
Voltage at pin 7 *	$I_{\text{fr}} = 0\ \mu\text{A}$, Test circuit 2 Pin 7	V_{7A}	15.3	16.0	16.7	V
Voltage at pin 7 *	$I_{\text{fr}} = 20\ \mu\text{A}$, Test circuit 2 Pin 7	V_{7C}		15.4		V
Parabola coefficient *	$K_1 = \frac{V_{7A} - V_{7B}}{V_{7A} - V_{7C}}$			26		%
Parabola coefficient *	$K_2 = \frac{V_{7A} - V_{7C}}{V_{7A} - V_{7D}}$			34		%
Difference *	$V_{\text{DET}} = V_{7E} - V_{7F}$		-40	0	40	mV
Current source	Test circuit 3 Pin 8	I_8		100		μA
Saturation voltage	$I_5 = 400\ \text{mA}$, Test circuit 4 Pin 5	V_{satL}		1	2	V
Saturation voltage	$I_5 = -100\ \text{mA}$, Test circuit 5 Pin 5	V_{satH}		0.8	1.5	V
Forward voltage	$I_5 = 400\ \text{mA}$, Test circuit 5 Pin 5	V_F		1.2	1.7	V
Forward voltage (substrate diode)	$I_5 = -100\ \text{mA}$, Test circuit 4 Pin 5	V_5		0.8	1.2	V

* see figure 2

90 6614 E

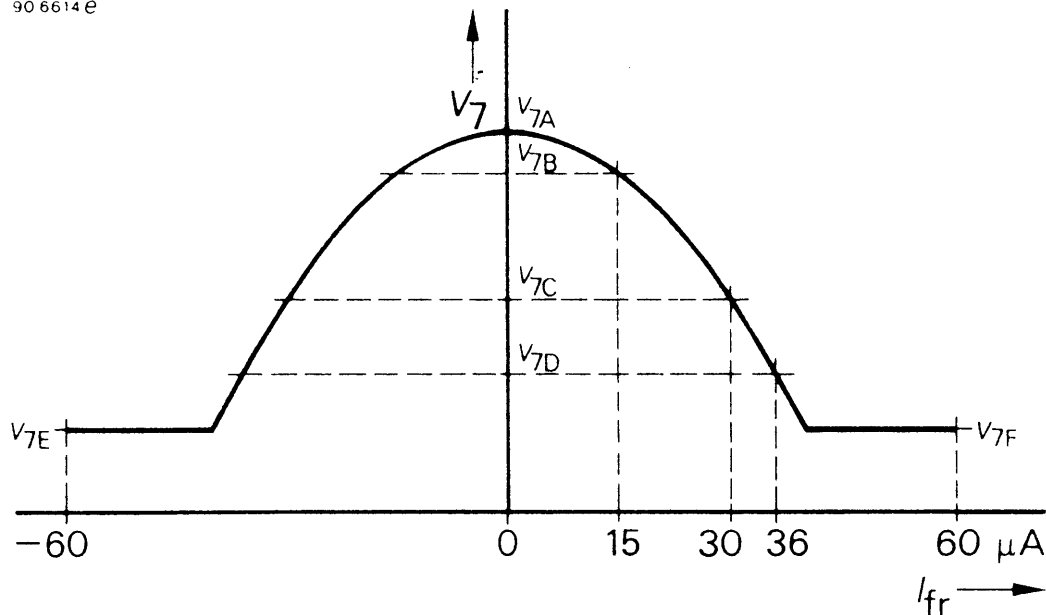

Figure 2 Parabola coefficients

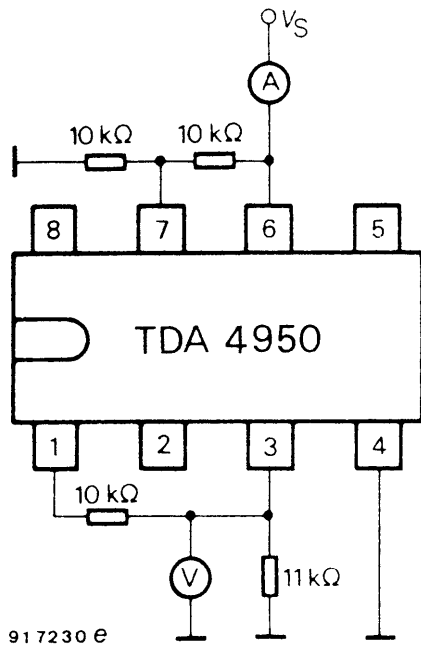

Figure 3 Test circuit 1

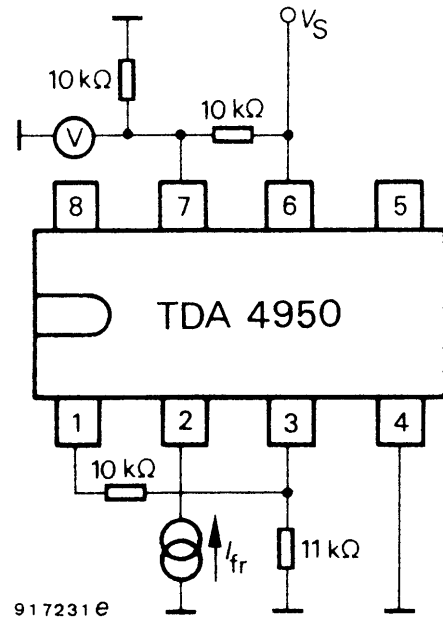

Figure 4 Test circuit 2

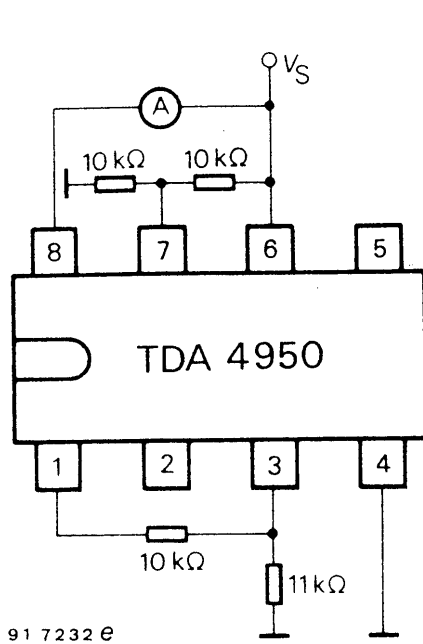

Figure 5 Test circuit 3

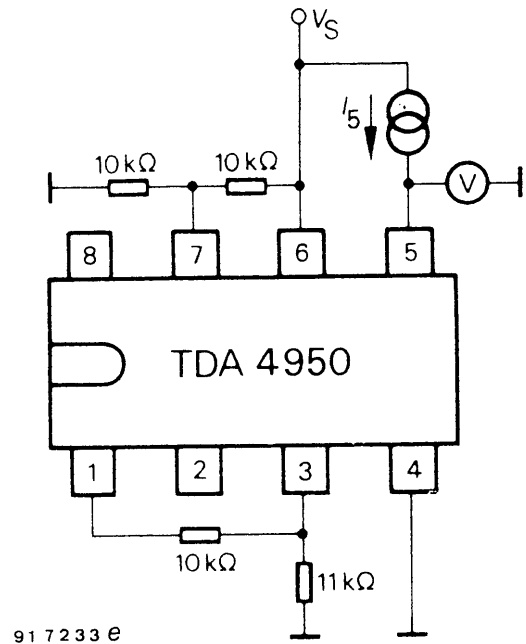

Figure 6 Test circuit 4

TDA 4951

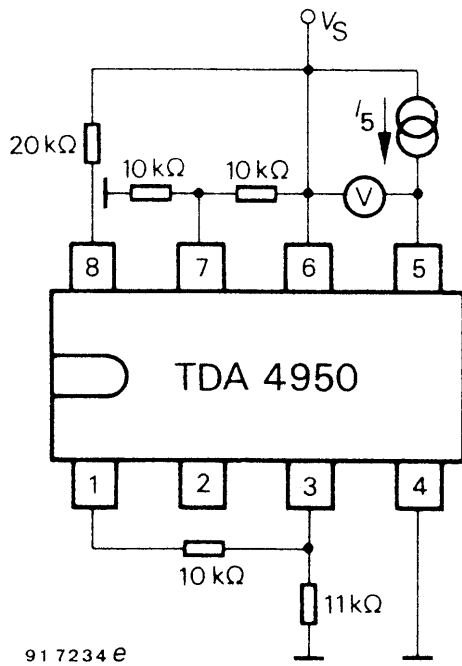
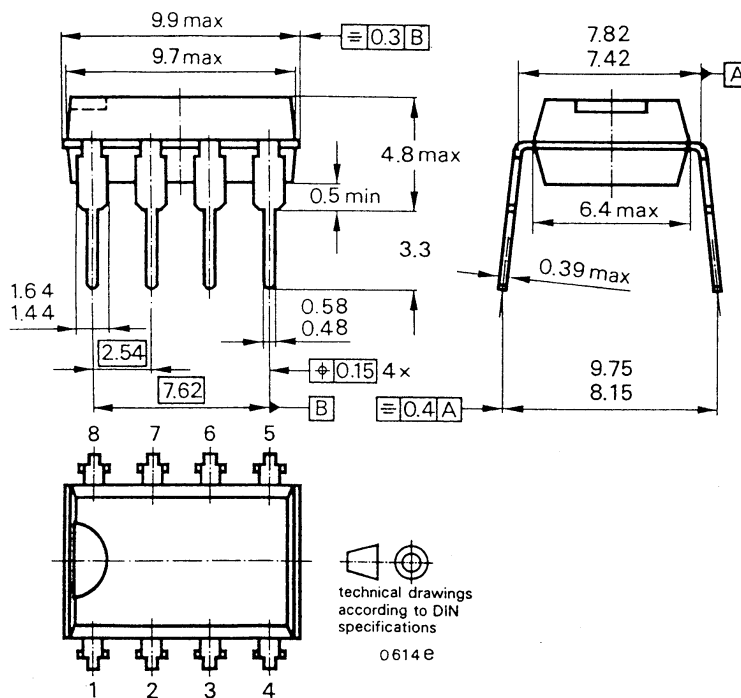

Figure 7 Test circuit 5

Dimensions in mm



Case
DIP 8

OZONE DEPLETING SUBSTANCES POLICY STATEMENT

It is the policy of **TEMIC TELEFUNKEN microelectronic GmbH** to

1. Meet all present and future national and international statutory requirements and
2. Regularly and continuously improve the performance of our products, processes, distribution and operating systems with respect to their impact on the health and safety of our employees and the public, as well as their impact on the environment.

Of particular concern is the control or elimination of releases into the atmosphere of those substances which are known as ozone depleting substances (ODSs).

The Montreal Protocol (1987) and its London Amendments (1990) will soon severely restrict the use of ODSs and forbid their use within the next ten years. Various national and international initiatives are pressing for an earlier ban on these substances.

TEMIC TELEFUNKEN microelectronic GmbH semiconductor division has been able to use its policy of continuous improvements to eliminate the use of any ODSs listed in the following documents.

1. Annex A, B and list of transitional substances of the Montreal Protocol and the London Amendments respectively
2. Class I and II ozone depleting substances in the Clean Air Act Amendments of 1990 by the Environmental Protection Agency (EPA) in the USA and
3. Council Decision 88/540/EEC and 91/690/EEC Annex A, B and C (transitional substances) respectively.

TEMIC can certify that our semiconductors are not manufactured with and do not contain ozone depleting substances.

We reserve the right to make changes to improve technical design without further notice.

Parameters can vary in different applications. All operating parameters must be validated for each customer application by the customer. Should the buyer use TEMIC products for any unintended or unauthorized application, the buyer shall indemnify TEMIC against all claims, costs, damages, and expenses, arising out of, directly or indirectly, any claim of personal damage, injury or death associated with such unintended or unauthorized use.

TEMIC TELEFUNKEN microelectronic GmbH, P.O.B. 3535, D-74025 Heilbronn, Germany
Telephone: 49 (0)7131 67 2831, Fax Number: 49 (0)7131 67 2423